

La utilidad de los números en la vida diaria.

1. Observa.

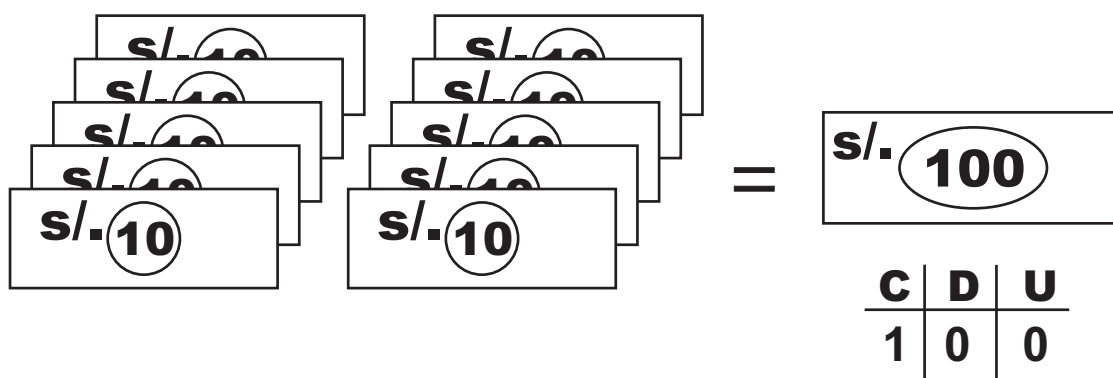



$$10 \times S/10 + 10 \times S/10 = S/100$$

C	D	U
1	0	0

2. Forma los siguientes números.

		C	D	U
$S/50 + S/10 = 60$	→	6	0	
$10 \times S/10 + 5 + 1 = 87$	→			
$S/50 + 10 \times S/10 + 1 + 1 + 1 = 96$	→			

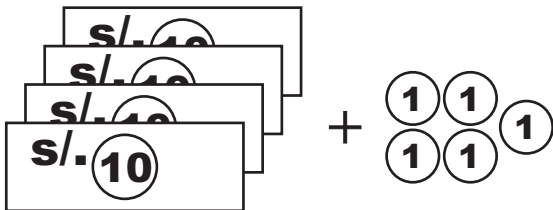
3. Escribe el número que corresponde.

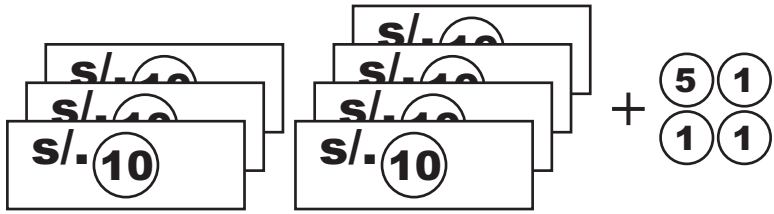
		D	U
	→		
	→		
	→		

4. Dibuja lo que te indica el número.



		D	U
→	3	2	
→	5	4	
→	6	9	



5. Completa las series.

$$\begin{array}{ccc} \textcircled{+10} & \textcircled{+10} & \\ 10 - 20 - & & - 100 \end{array}$$

$$\begin{array}{ccc} \textcircled{-10} & \textcircled{-10} & \\ 100 - 90 - & & - 10 \end{array}$$

6. Escribe los números del 51 al 100.

51 - _____

61 - _____

71 - _____

81 - _____

91 - _____

7. Escribe el número posterior (después de...)

53	_____		69	_____		89	_____
19	_____		55	_____		99	_____



8. Escribe el número anterior (antes de...)

_____	30		_____	60		_____	95
_____	100		_____	75		_____	51

Hazlo TÚ mismo

★ **Completa las series.**

$\textcircled{+2}$ $\textcircled{+2}$ $\textcircled{+2}$
63, 65, 67, ____, ____, ____, ____, 77, 79, 81

$\textcircled{-1}$ $\textcircled{-1}$ $\textcircled{-1}$
70, 69, 68, ____, ____, ____, ____, 63, 62, 61

$\textcircled{+1}$ $\textcircled{+1}$ $\textcircled{+1}$
86, 87, 88, ____, ____, ____, ____, 93, 94, 95

★ **Escribe los números anterior y posterior.**

___ 59 ___	___ 75 ___	___ 61 ___
___ 99 ___	___ 40 ___	___ 80 ___

★ **Realiza cálculos rápidos.**

$30 + 10 = \underline{\hspace{2cm}}$ $50 + 20 = \underline{\hspace{2cm}}$ $80 + 10 = \underline{\hspace{2cm}}$

$40 + 10 = \underline{\hspace{2cm}}$ $70 + 20 = \underline{\hspace{2cm}}$ $90 + 10 = \underline{\hspace{2cm}}$

$100 - 10 = \underline{\hspace{2cm}}$ $40 - 10 = \underline{\hspace{2cm}}$ $80 - 20 = \underline{\hspace{2cm}}$

$90 - 10 = \underline{\hspace{2cm}}$ $20 - 10 = \underline{\hspace{2cm}}$ $70 - 20 = \underline{\hspace{2cm}}$